



WELCOME

AESQ Supplier Forum

Hosted by

Rolls-Royce Civil Aerospace

Seletar Country Club, Singapore

April 6th 2017

AESQ – Aero Engine Supplier Quality Strategy Group

This document slide does not contain ITAR or EAR technical data. The content of this presentation slide is proprietary and confidential information of the AESQ. It is not permitted to be distributed to any third party without the written consent of the AESQ.

Overview of the Day

Seletar Aerospace Park

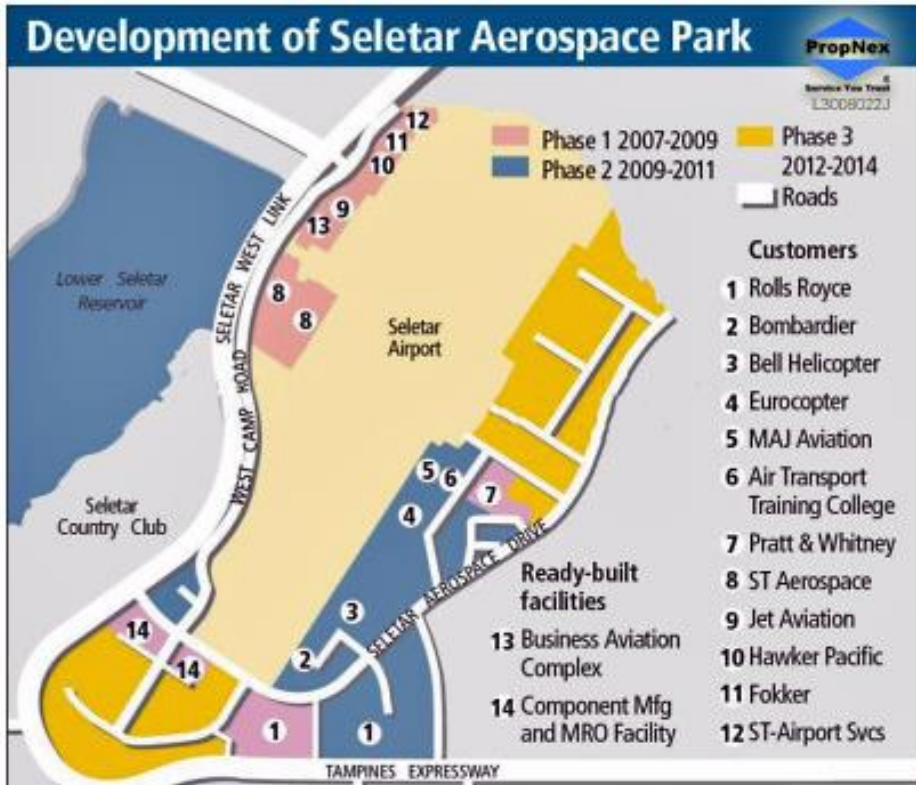

AESQ - Aero Engine Supplier Quality Strategy Group

This document slide does not contain ITAR or EAR technical data. The content of this presentation slide is proprietary and confidential information of the AESQ. It is not permitted to be distributed to any third party without the written consent of the AESQ.

Overview of the Day

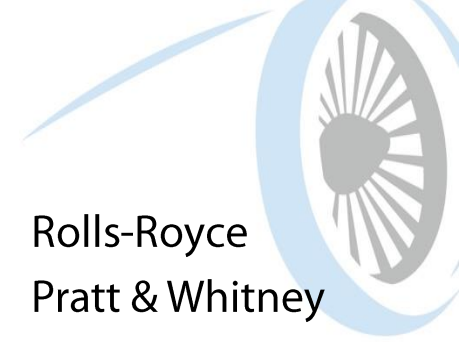

09:00	Introduction & Overview	Dr Ian Riggs	Rolls-Royce
09:30	Challenges within the Supply Chain	Peter Amsden	Pratt & Whitney
10:00	The Need for Defect Prevention	John Calder	Rolls-Royce
10:30	Coffee Break & Networking		
11:00	Overview of the AESQ Standards	Olivier Castets	Safran
		Dave Goldberg	GE Aviation
12:00	Lunch & Networking		
13:00	Standards Market Place	AESQ Committee	
14:00	Coffee Break & Networking		
14:30	Standards Market Place	AESQ Committee	
15:15	Benefits of Standard Deployment	Bhu Kenjale	PCC
		Helen Djäknegren	GKN
		Martin Schaeffner	MTU
16:00	Market Place Debrief	Peter Amsden	Pratt & Whitney
16:15	Closing Remarks	Dr Ian Riggs	Rolls-Royce

Burning Platform

- Increasing supplier / partner engine content
- Wide range of Aerospace engine supplier businesses <\$1M to \$2B+
- Increasing global footprint
- Overlap of engine suppliers between engine manufacturers
- Demanding Customers
- Improving Quality, Cost and Delivery is a key challenge



Aerospace Engine Supply Chain

Customer vs. Supplier Perceptions of Quality Requirements



- Customer Perception

- Reactive : Focus on inspection to sort 'good' from 'bad'
- Poor compliance
- Limited application of Process Control
- Low maturity of defect prevention and quality planning processes
- Little Continuous Improvement activity

- Supplier Perception

- Complex requirements set independently by each Customer
- High levels of external audit with inconsistent interpretations
- No common language for Quality
- High levels of customer control and intervention

AESQ Vision



To establish and maintain a common set of Quality Requirements that enable the **Global Aero Engine Supply Chain** to be truly competitive through lean, capable processes and a culture of Continuous Improvement.

Aero Industry Requirements Flowdown

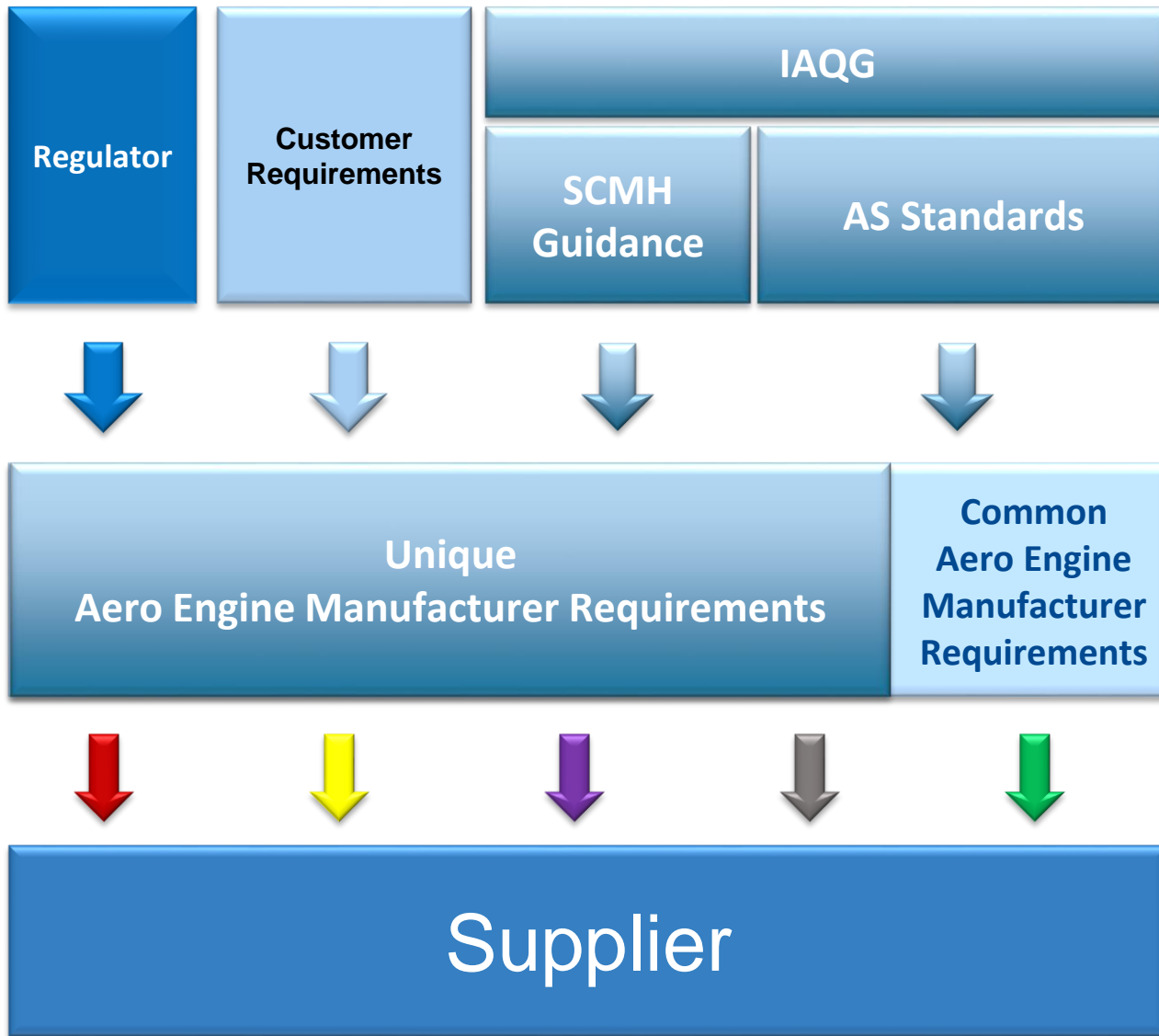

AESQ - Aero Engine Supplier Quality Strategy Group

This document slide does not contain ITAR or EAR technical data. The content of this presentation slide is proprietary and confidential information of the AESQ. It is not permitted to be distributed to any third party without the written consent of the AESQ.

Aero Industry Requirements Flowdown

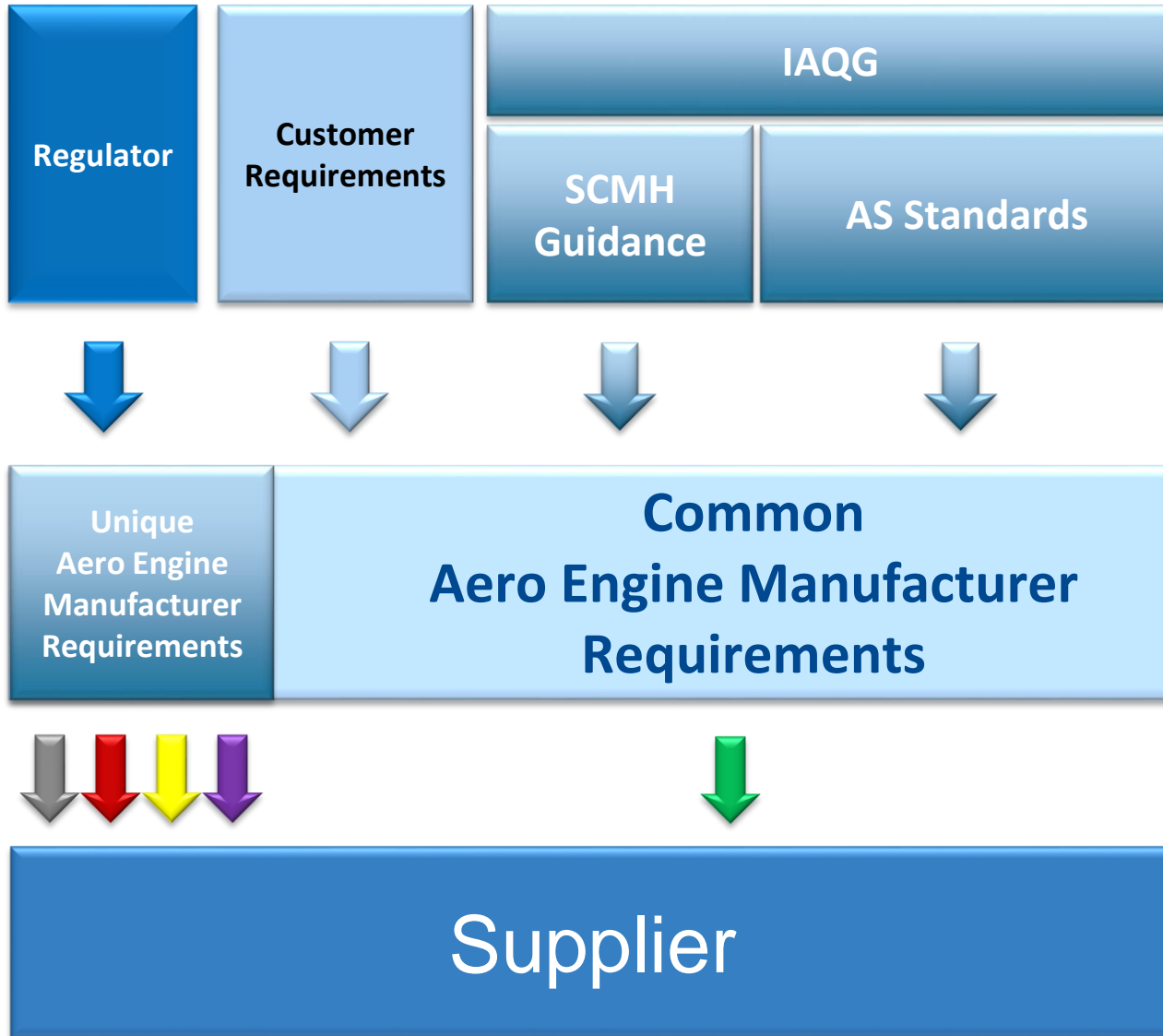

AESQ - Aero Engine Supplier Quality Strategy Group

This document slide does not contain ITAR or EAR technical data. The content of this presentation slide is proprietary and confidential information of the AESQ. It is not permitted to be distributed to any third party without the written consent of the AESQ.

AESQ Guiding Principles



Simplify & Standardize supplier requirements

Build on existing industry standards

Common language for Quality

Standards are simple, prescriptive & auditable

Promote standardized 3rd party training

Easy to adopt within existing process/systems

Deliver results rapidly, through focused activities



G-22 Aerospace Engine Supplier Quality



G-22 Technical Committee

Aero Engine Manufacturers & Suppliers



GE
Aviation



GKN AEROSPACE

Honeywell



PCC *Structurals, Inc.*



Rolls-Royce



ARCONIC



Pratt & Whitney

A United Technologies Company



SAFRAN

Supplier Representatives

AESQ - Aero Engine Supplier Quality Strategy Group

This document slide does not contain ITAR or EAR technical data. The content of this presentation slide is proprietary and confidential information of the AESQ. It is not permitted to be distributed to any third party without the written consent of the AESQ.

How you can participate

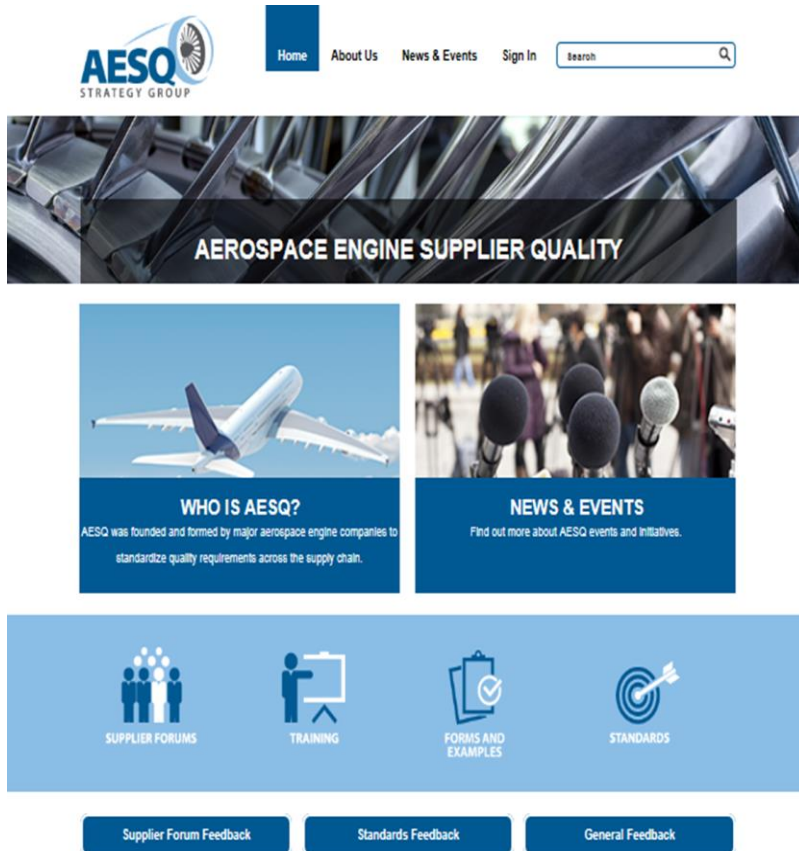

- Attend our AESQ Supplier Forums
 - Share your views and experiences of our current standards
 - Help to identify new areas of work for the group
- Provide feedback on current and developing standards via the AESQ Website
- Share best practice deployment stories via the website and Forums
- Contact us through the AESQ website

<http://aesq.saeitc.org/>

AESQ – Aero Engine Supplier Quality Strategy Group

This document slide does not contain ITAR or EAR technical data. The content of this presentation slide is proprietary and confidential information of the AESQ. It is not permitted to be distributed to any third party without the written consent of the AESQ.

Meeting protocols

Welcome to the
G22-AESQ Technical Committee

AESQ Code of Conduct



- Audio/video recording of meetings is not permitted
- No Commercialism
 - No discussion of cost, pricing plans, pricing policies, product usage surveys, marketing plans or any related topics
- Presentations must focus on technical issues (not on marketing aspects of products) and relate to or support the development or maintenance of G-22 Committee work
- Be aware of and follow ITAR & EAR rules and regulations governing export control
- Discussions should be open and follow the agenda or other legitimate direction agreed upon by consensus of the committee - avoid unauthorized or 'private' meetings

AESQ Code of Conduct



- Strive for high-quality standards to benefit all stakeholders – users, customers, suppliers and the industry as a whole
- Strive for an open atmosphere that promotes a free-flowing interchange of standards technical information
- Respect basic meeting etiquette:
 - Only one person speaking at any given time
 - Attack the issue, not the person
 - Be on time...returning from breaks/lunch
 - Respect all ideas & comments
 - No silent skepticism, be candid
 - Do not dominate discussions
 - Stay focused on the meeting & agenda

The Need for Defect Prevention

AESQ – Aero Engine Supplier Quality Strategy Group

This document slide does not contain ITAR or EAR technical data. The content of this presentation slide is proprietary and confidential information of the AESQ. It is not permitted to be distributed to any third party without the written consent of the AESQ.

How do we achieve Perfect Quality???

- 100% inspection
- Sorting good from bad
- Concessions to accept non-conforming product
- Overrun parts to ensure delivery commitments
- 3rd Party inspection



Focus on defect prevention – How effective is 100% inspection?

- Individually inspect the image to the standard
- Items needed
 - Standard
 - Marking sheet and a pen
- Compare the image to the standard and check “pass or fail”



Focus on defect prevention –

How effective is 100% inspection?

- Discuss on your tables how effective is 100% inspection
- Would 200% be better?
- What can we do as part of defect prevention?
- Prepare for feedback



Focus on defect prevention

Defect Prevention

- No room for customer disruption
- Capacity released
- Predictable planning
- Cost challenges supported
- Focus on growth opportunities



Defect Prevention Tools

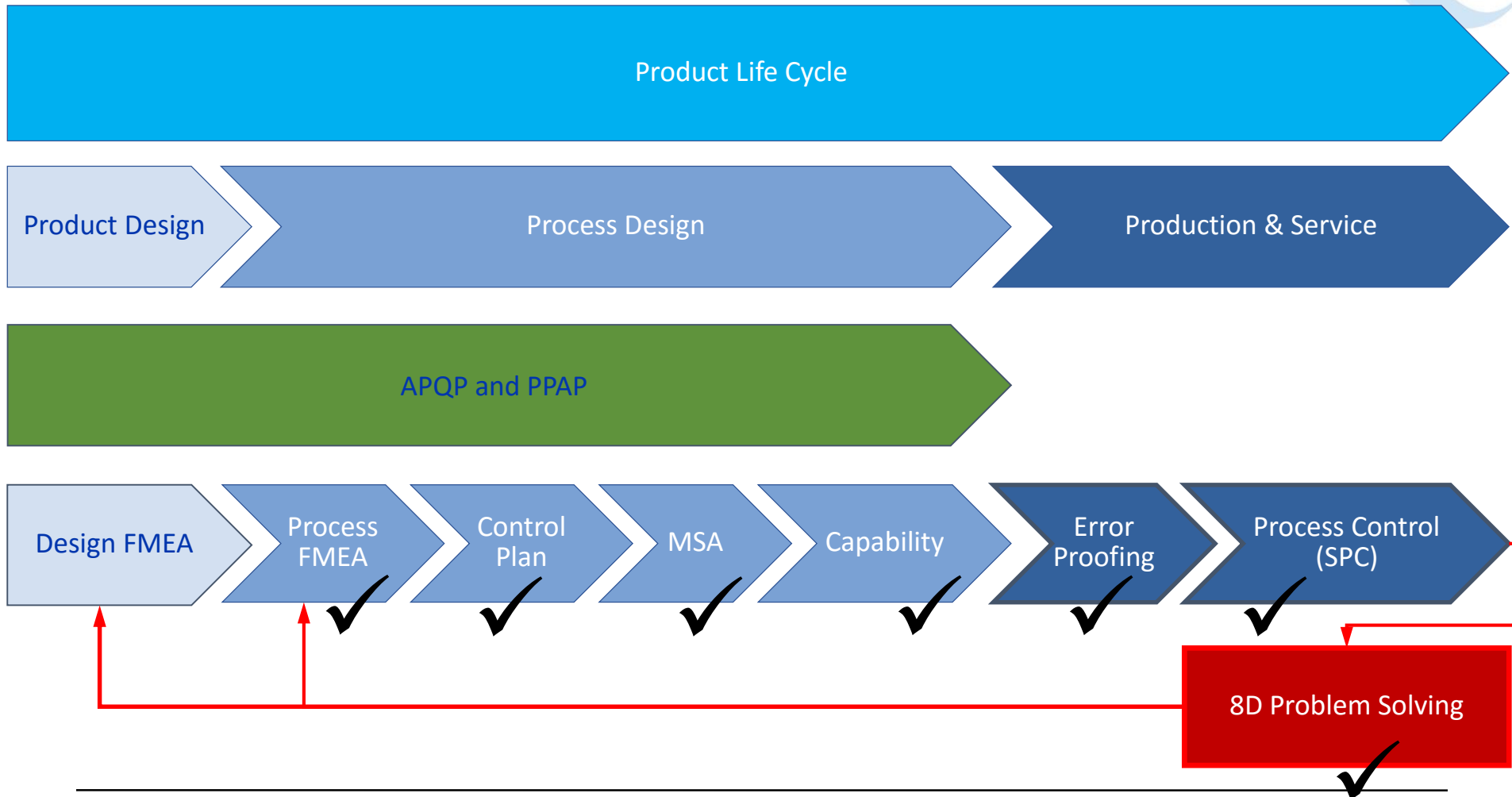

How we work

Standards overview



SAE ITC / SAE G-22 Structure

AESQ Strategy Group

- Companies**
- Strategy
- Training
- Deployment
- Promotion & Communication
- Customer, Regulator & IAQG Interface
- Administration

G-22 Technical Committee

- Individuals**
- Standards Writing



AESQ Website

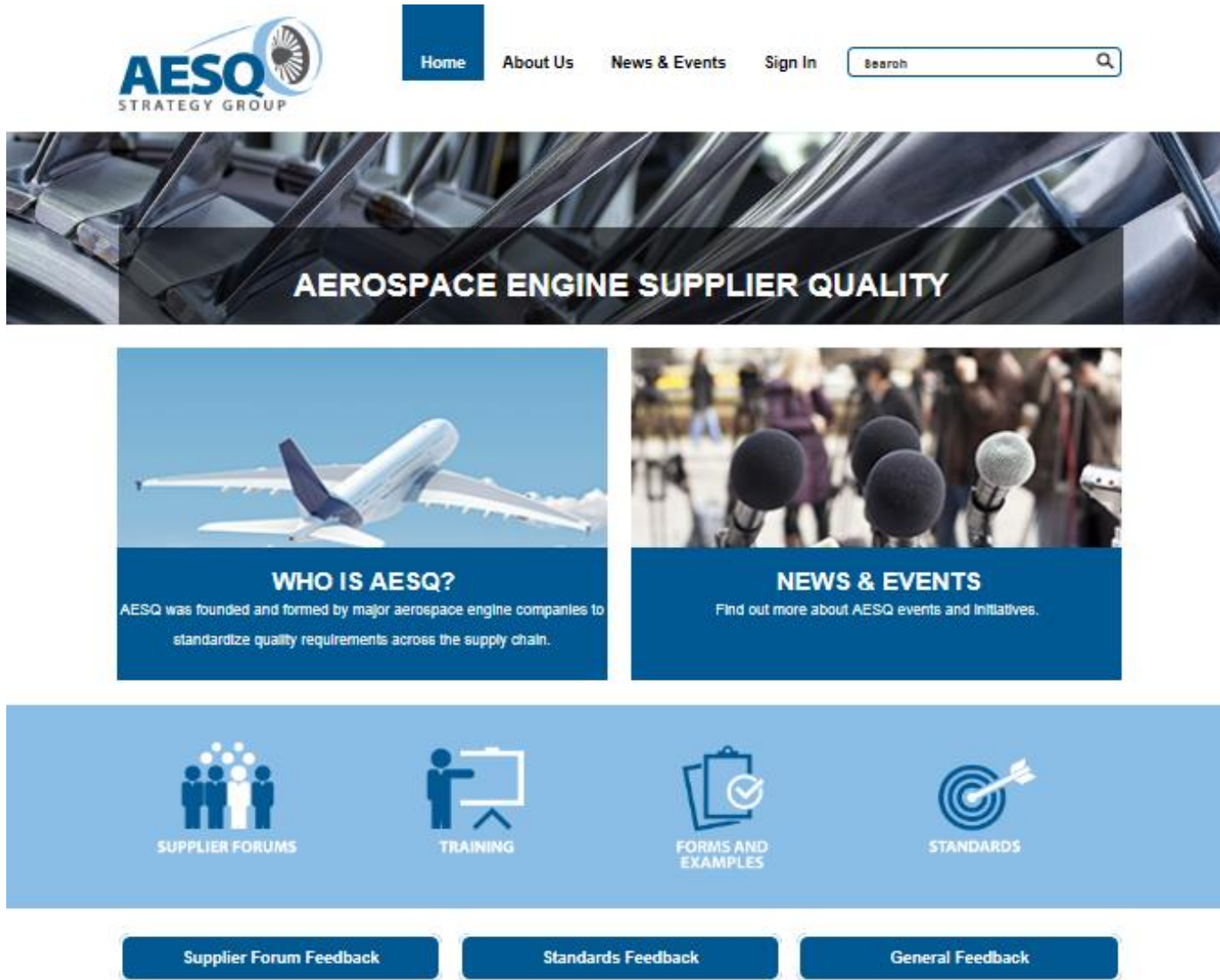

AESQ – Aero Engine Supplier Quality Strategy Group

This document slide does not contain ITAR or EAR technical data. The content of this presentation slide is proprietary and confidential information of the AESQ. It is not permitted to be distributed to any third party without the written consent of the AESQ.

Existing & Future Workstreams

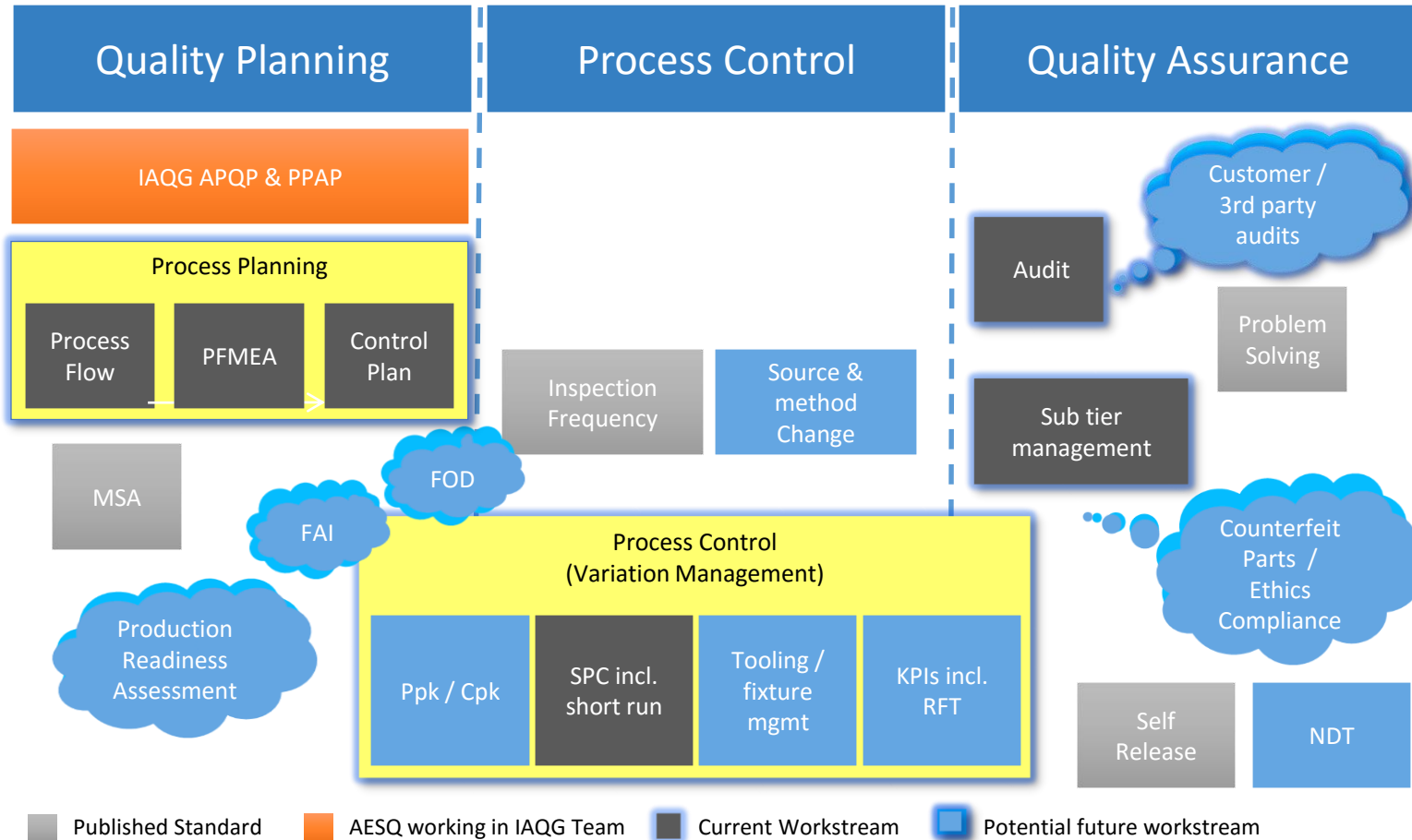

AS13000 Problem Solving

Original State



Current State

GLOBAL 8D



AESQ Principles

- Standardise
- Simplify
- Adopts Existing Industry Standards
- Prescriptive, Auditable
- Common Language
- Supported by 3rd Party Training & Consultancy

Expected Benefits

- Reduced need for Customer training & support
- Improved access to training & consultancy
- Removal of complexity of reporting
- Improved problem solving skills



AS13001 Supplier Self Release Training

Original State



Current State



- One Common Training Requirement
- Industry wide DQR database through SAE
- Delivered by SAE Globally
- Refresher training every 3 years

AESQ Principles

- Standardise
- Simplify
- Adopts Existing Industry Standards*
- Prescriptive, Auditable
- Common Language
- Supported by 3rd Party Training & Consultancy

Expected Benefits

- Reduced costs for the supplier
- Reduced training time for DQR
- Training provided in Supplier's region
- Customer training limited to on-site

* Rev A to align with AS9117 - DPRV



AS13002 Inspection Frequency



Original State

100% Inspection

REDUCED

Sample

Error Proof

AQL

Current State

100%

Inspection Level

Capability

- Common Method for Inspection Planning
- Guidance on commodity specific planning

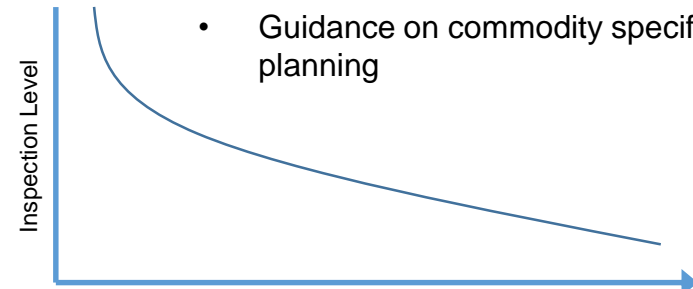

AESQ Principles

- Standardise
- Simplify
- Adopts Existing Industry Standards
- Prescriptive, Auditable
- Common Language
- Supported by 3rd Party Training & Consultancy

Expected Benefits

- Standardised Process
- Improved compliance
- Improved Product Quality

AS13003 Measurement Systems Analysis



Original State



Current State

Method	Feature Category			
	Critical	Major		
Resolution	≤10% of total tolerance			
Accuracy ratio**	Requirement = 10:1			
Accuracy Error / Bias	≤10% of total tolerance			
Repeatability	≤10% of total tolerance	≤20% of total tolerance		
Gauge R&R	≤10% of total tolerance	≤20% of total tolerance	≤30% of total tolerance*	Purchaser requirements may override this
Computer driven measurement systems correlation	≤10% of total Tolerance		≤20% of total Tolerance	Purchaser requirements may override this
Linearity**	≤1% of total tolerance		-	
Attribute Study: pass/fail	Kappa ≥ 0.8		-	Only required on operator dependent interpretation
Attribute study: ordinal	ICC ≥ 0.75		-	Only required on operator dependent interpretation



AESQ Principles

- Standardise
- Simplify
- Adopts Existing Industry Standards
- Prescriptive, Auditable
- Common Language
- Supported by 3rd Party Training & Consultancy

Expected Benefits

- Improved knowledge of Measurement Capability
- Clarification of minimum acceptance standards
- Mandates replaces guidance
- Adopts Automotive Industry Action Group 'Blue Book' on MSA
- Improved Quality Performance

AS13005 Internal Audits Requirements

Original State

Internal audit requirements in many documents

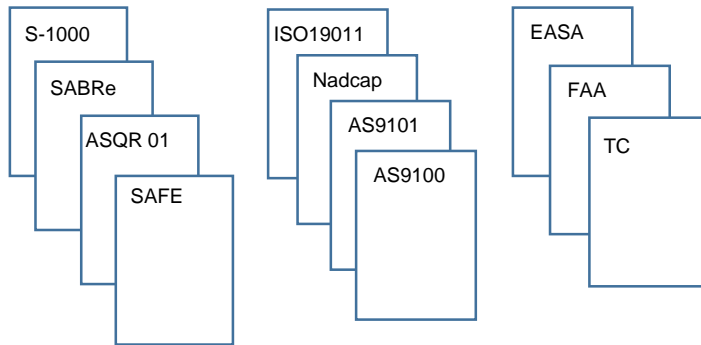

Future State

Content



- Audit types & checklists (examples)
 - System
 - Production process
 - Product
 - Special process
- Auditor qualification
- Audit KPI's
- Audit criteria

In scope: Internal audits for suppliers

Out of scope: 2nd/3rd party audits (e.g. Customer audits).

AESQ Principles

- Standardise
- Simplify
- Adopts Existing Industry Standards
- Prescriptive, Auditable
- Common Language
- Supported by 3rd Party Training & Consultancy

Expected Benefits

- Lean & effective internal audit process providing confidence in state of compliance throughout Aero-Engine supply chain
- Reduced and/or eliminated unnecessary and/or duplicate audits

AS13006 Process Control

Original State



Varying standards & approaches

- PC requirements not clearly defined/understood
- Inconsistent application/flowdown to sub-tiers
- Lack of commitment/belief in benefits
- Belief low volume environments not applicable

Future State

Common standard & approach
Aligned with AS13002, 13003, 13004, AS9103,
AS9145 & AIAG “Blue Books”



In scope: Process Control for all characteristics

Out of scope: Foundational requirements

AESQ Principles

- Standardise
- Simplify
- Adopts Existing Industry Standards
- Prescriptive, Auditable
- Common Language
- 3rd Party Training & Consultancy

Expected Benefits

- Improved variation control & reduction techniques, broad-based belief in benefits
- Common prescriptive standard fully aligned with AESQ, AS9103 & AIAG Blue Book Stds
- Focus on accurate data analysis and proactive problem resolution
- Improved Quality Performance, reduced risk

AS13007 Supplier Management

Original State



Varied Customer-Specific Requirements

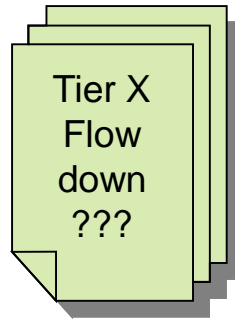

Future State



Fewer Customer-Specific Requirements

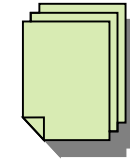

In scope: Raw material & finished hardware
Out of scope: Distributors & MRO suppliers

AESQ Principles

- Standardise
- Simplify
- Adopts Existing Industry Standards
- Prescriptive, Auditable
- Common Language
- Supported by 3rd Party Training & Consultancy

Expected Benefits

- Simplify language for organizations to manage suppliers
- Ability to use the standard throughout all tiers of the supply chain
- Standard will simplify and reduce the number of methods the suppliers must use to meet Customer requirements (i.e. simplify/make common the "how to")

AS13008 Supplier Audit

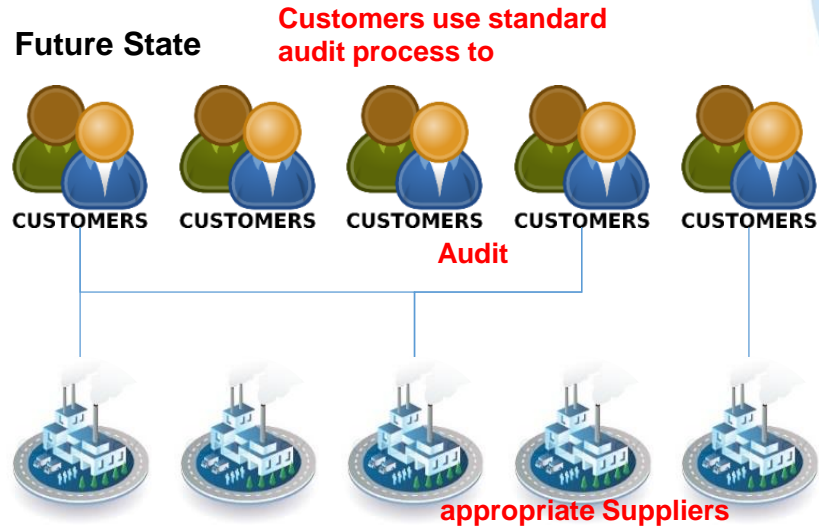
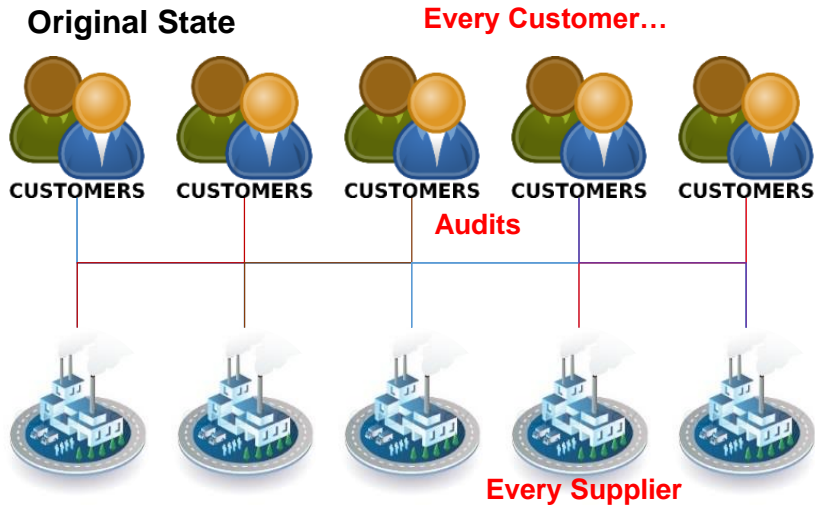

AESQ Principles

- Standardise
- Simplify
- Adopts Existing Industry Standards
- Prescriptive, Auditable
- Common Language
- Supported by 3rd Party Training & Consultancy

Expected Benefits

- Standard customer audit process aligned to AS13005
- Improved rigor of audit approach
- Suppliers chosen for audit based on risk (performance and risk)
- Reduced supplier audits for good performing suppliers (low risk) that demonstrate compliance to AS13005
- Recognizes existing 3rd party certification
- Cost reduction / resources liberated by customer and supplier.

Product Life Cycle & Document Interaction



AS9145 (APQP/PPAP) & AESQ Standards

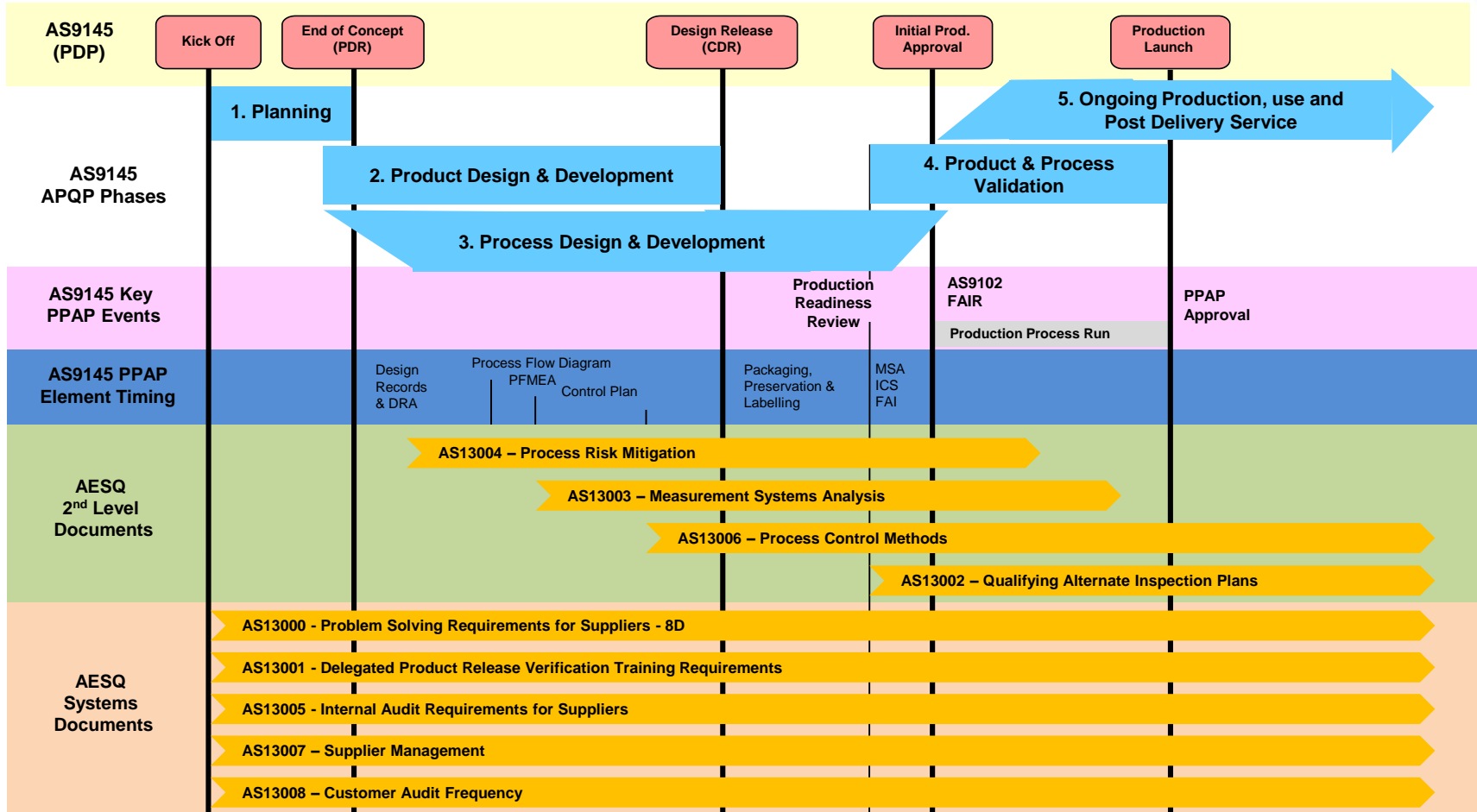

AESQ – Aero Engine Supplier Quality Strategy Group

This document slide does not contain ITAR or EAR technical data. The content of this presentation slide is proprietary and confidential information of the AESQ. It is not permitted to be distributed to any third party without the written consent of the AESQ.

AESQ Standards - Global Deployment



• Vision

- Deploy harmonically
- Challenge each other
- Common language for Quality
- Easy adoption of standards
- Simplify requirements

AESQ Standards - Global Deployment Status

	AS13000 Problem Solving (8D)	AS13001 Supplier Self-Release	AS13002 Inspection Frequency	AS13003 MSA	AS13004 Process Risk Mitigation
AESQ Member	Accepted	Accepted	Accepted	Accepted	Accepted
GE					Upon Release
GKN					Upon Release
Honeywell					Upon Release
MTU					Upon Release
PCC Structurals					Upon Release
Pratt & Whitney					Upon Release
Rolls-Royce					Upon Release
Safran					Upon release

